

IN PRESS ----- PLEASE DO NOT QUOTE

Strengths, Limitations, and Extensions of LSA

Xiangen Hu

Zhiqiang Cai

Peter Wiemer-Hastings

Art C. Graesser

Danielle S. McNamara

University of Memphis

Abstract

The strength of Latent Semantic Analysis (LSA) (Deerwester, Dumais, Furnas, Landauer, & Harshman, 1990, Landauer & Dumais, 1997) has been demonstrated in many applications, many of which are described in this book. This chapter briefly describes how LSA has been effectively integrated in some of the applications developed at the Institute for Intelligent Systems, the University of Memphis. The chapter subsequently identifies some weaknesses of the current use of LSA and proposes a few methods to overcome these weaknesses. One problem addresses statistical properties of an LSA space when it is used as a measure of similarity, while the second problem addresses the limited use of dimensional information in the vector representation. With respect to the statistical aspect of LSA, we propose using the standardized value of cosine matches for similarity measurements between documents. Such standardization is based on both the statistical properties of the LSA space and the properties of the specific application. With respect to the dimensional information in LSA vectors, we propose three different methods of using LSA vectors in computing similarity between documents. The three methods adapt to (1) learner perspective, (2) context, and (3) conversational history. These adaptive methods are assessed by examining the relationship between LSA similarity measure and keyword-match based similarity measures. We argue that LSA can be more powerful if such extensions are appropriately used in applications.

Introduction

As the title indicates, this chapter addresses three goals. The first goal is to identify some important strengths of LSA whereas the second is to identify some weaknesses. The third goal is to propose a few alternative quantitative models of representation with high-dimensional semantic spaces. As amply demonstrated by the range of applications described in other chapters of this book, there is no need to address the practical strength of LSA. Instead, we approach the first goal by presenting some basic facts about LSA in terms of simple algebra and demonstrate how powerfully this “data-mining” method captures human intuition. Limitations of LSA are observed from two perspectives: empirical evaluations of LSA in applications and formal analysis of LSA algorithms and procedures. Regarding the third goal, we position LSA in a more general framework and then examine possible extensions. These extensions include three methods which adapt (1) to learner perspective (2) context, and (3) conversational history.

Comparing text similarity

The primary task that LSA performs in most applications is to compute the semantic similarity of any two texts. To approach LSA from a different angle, we consider two other text similarity metrics: word-based and context-based measures of text similarity. The discussion of these relatively simple measures will facilitate the introduction of a denotation that allows the consideration of LSA in a new framework.

Word-based Similarity

Keyword matching is the most frequently used method to measure similarity between two texts. There are many different techniques for keyword matching. We list a few in the order of simplicity.

Word Matching: The simplest technique is word matching. In this case, all words are of

equal importance and the calculation is based on how many words the two texts share. This method does not depend on context or domain knowledge. The similarity measure is a function of the total words and the shared words, which can readily be depicted in a Venn diagram (<http://www-groups.dcs.st-and.ac.uk/~history/Mathematicians/Venn.html>). The most often-used formula for the computation is the ratio of the shared words to the total words, which restricts the similarity measure between 0 (completely different) and 1 (completely identical). The advantages of word matching are its intuitiveness and computational simplicity. One disadvantage of this method is the lack of emphasis on important words. The next method improves the word matching method by considering which words contribute most to the distinct meaning of the text.

Keyword Matching: In this case, only keywords are considered. Common words or function words like *it*, *is*, or *the* are ignored (Graesser, Hu, Person, Jackson, and Toth, 2004). This is the most widely used method in document retrieval. The advantage of this method is that it considers the importance of the words' semantic contributions. Some additional requirements need to be satisfied in order to have this method work well, especially in narrowly-defined domains. For example, which words are identified as keywords largely depends on the domain. In most cases, the list of keywords is simply the list of glossary items and therefore is domain dependent. One weakness of this method is that it does not consider differential importance as to how much information a particular word may carry. The following method addresses this problem by differentially weighting the keywords.

Weighted Keyword Matching: The advantage of weighting keywords is to emphasize the degree to which a particular word is important to a particular domain. The challenge lies in how to assign the weights, which is often domain dependent. For example, weights can reflect how often a word is used in ordinary written language or spoken language (Graesser, Hu, et., 2004). Such data

can be obtained either by computing the relative frequency from a given corpus (with a one-time computation cost), or by using an established lexical database such as WordNet (Miller, 1985) or the MRC Psycholinguistic Database (Coltheart, 1981). As an alternative, weights can be assigned by an algorithm that computes the importance of the word in context. However, such an algorithm would need to be formulated in a principled fashion and might again depend heavily on domain expertise.

Weighted keyword matching is a powerful abstraction which subsumes word matching and keyword matching. It is also flexible due to the unlimited methods of assigning weights. However, it is limited in that it relies on exact matches between words. The extended weighted keyword matching methods allows consideration of synonyms as well.

Extended Weighted Keyword Matching: This method simply considers each word together with a set of words that are similar in some fashion. For example, each word can be associated with a set of synonyms. This method can provide a similarity rating even when the compared texts do not have any exact words in common. In such cases, the use of synonyms can also be a liability. Synonyms never capture exactly the same meaning as the original word, especially when one considers a range of contexts of use. Thus the inclusion of synonyms has the potential to significantly distort the meanings of the texts.

Each of the methods mentioned above operates by finding exact matches between words. The information affiliated with a word (i.e. its weight and synonyms) can either be calculated by some method from a corpus, or taken from an external resource. As such, the performance of the techniques can depend heavily on the resources used. Databases such as MRC (Coltheart, 1981) and CELEX (<http://www.ru.nl/celex/>) can provide word frequency information. Corpora such as TASA (Touchstone Applied Science Associates, Inc.), Penn Treebank

(<http://www.cis.upenn.edu/~treebank/home.html>), and the British National Corpus (BNC, <http://www.natcorp.ox.ac.uk/>) provide samples of actual texts from which word information can be derived. A lexicon like WordNet (<http://wordnet.princeton.edu/>) can provide synonyms. The information derived from different lexical databases or corpora may be appropriate for the domain of interest, but it may also be misleading if there is a misalignment between the corpus and the application. The quality of this information can have a large effect on the overall success of the technique.

Formal definition of similarity between texts

The various types of word matching methods can be represented within a unified mathematical formalism. First, consider that the collection of all possible terms in a given language is a set with m items. One can index all the terms from 1 to m . Each term t_i (where $i=1, \dots, m$) can be represented by an m -dimensional row vector with only one nonzero element. Denoting the i^{th} row vector by \mathbf{t}_i and the j^{th} entry of the i^{th} row by u_{ij} , we have

$$\mathbf{t}_i = (u_{ij})_{j=1}^m, \quad (1)$$

where

$$u_{ij} = \begin{cases} 1 & j = i \\ 0 & \text{otherwise} \end{cases}. \quad (2)$$

In other words, \mathbf{t}_i is a vector which is 0 everywhere except for the i^{th} element which is 1. With this notation, for any text T with K words (not necessarily distinct), there is an m dimensional vector representation \mathbf{T} , as expressed in equation Eq(3) in which there are K term vectors in the summation:

$$\mathbf{T} = \sum_i n_i \mathbf{t}_i. \quad (3)$$

where n_i is the number of occurrences of the i^{th} word in the text T .

The word match similarity between two texts, \mathbf{T}_1 and \mathbf{T}_2 is computed as the cosine between the two document vectors:

$$\cos(\mathbf{T}_1, \mathbf{T}_2) = \frac{\mathbf{T}_1 \mathbf{T}_2^T}{\sqrt{\mathbf{T}_1 \mathbf{T}_1^T} \sqrt{\mathbf{T}_2 \mathbf{T}_2^T}}. \quad (4)$$

Notice that \mathbf{T}_1 and \mathbf{T}_2 are row vectors, so there is a transpose needed for \mathbf{T}_2 in Eq(4).

Assembling all the term vectors together, a diagonal matrix \mathbf{U} can be obtained, as expressed in Eq(5).

$$\mathbf{U} = \begin{pmatrix} n_1 \mathbf{t}_1 \\ \vdots \\ n_m \mathbf{t}_m \end{pmatrix} = (\mathbf{u}_{ij})_{m \times m} \quad (5)$$

With this definition of \mathbf{U} , we are able to have similar formulas for different types of similarity measures.

Keyword matching and weighted keyword matching

Consider an $m \times m$ diagonal matrix, $\mathbf{W} = \text{diag}\{w_i\}$, where all diagonal elements are non-negative. In this case, the similarity measure based on both keyword matching and weighted keyword matching can be computed with Eq(4), where the term vector \mathbf{t}_i is multiplied by the number of occurrence to form the i^{th} row of \mathbf{WU} . In other words, the matrix \mathbf{WU} contains term vectors \mathbf{t}_i multiplied by the occurrences and then weighted by w_i ($i = 1, \dots, m$). Note that keyword matching corresponds to the case where elements of \mathbf{W} only have the value of 0 or 1. A weight of 0 for a common word essentially removes it from consideration.

Extended Weighted Keyword Matching

The similarity measure corresponds to extended weighted keyword matching can be computed as the as Eq(4), where $\mathbf{T} = \mathbf{WUE}$ and $\mathbf{E} = (e_{ij})_{m \times m}$ is a matrix with all elements either 0 or 1. When $e_{ij} = 1$, terms indexed as i and j are synonyms of each other.

We find the above notations very useful. We can extend the similarity measures from word matching to context matching.

Context-based Similarity

In the word-based methods, the only way that one could obtain a nonzero similarity measure between two distinct terms is when they are somehow related. This occurs, for example, when there is extended weighted keyword matching and the two terms are synonyms. A similarity measure based on context is different from the keyword-based similarity measure. Consider a corpus, with all of the documents indexed from $1, 2, \dots, n$. Term t_i , $i=1, \dots, m$, in the corpus is represented as the n -dimensional vector expressed in Eq(6),

$$\mathbf{t}_i = \left(f_{ij} \right)_{j=1}^n, \quad (6)$$

where f_{ij} is the number of times term t_i appears in document j . Denote $\mathbf{F} = \left(f_{ij} \right)_{m \times n}$. The similarity measure of any two texts based on context can again be computed with Eq(4), where \mathbf{t}_i is the i^{th} row of \mathbf{F} . As with the word-based measures, we can also apply weighting to terms and documents. In this case, term weights form a diagonal matrix $\mathbf{W}_{m \times m}$ and document weights form a diagonal matrix $\mathbf{\Lambda}_{n \times n}$. The similarity measures between two texts is the same as Eq(4), except that the term vector \mathbf{t}_i is obtained as the i^{th} row of $\mathbf{WF}\mathbf{\Lambda}$. This method of denotation allows us to consider LSA in a new framework, as discussed in the next section.

LSA

The two similarity measures introduced previously have one important common characteristic: the terms are represented as multidimensional vectors. The computational formulas are the same, namely Eq(4). However, the vector representations of the terms differ between the approaches. As we have observed, for all the methods introduced, we always assume the existence

of a high dimensional vector representation. This assumption will bring some difficulty when they are implemented in real applications due to the computational complexity.

Representing terms as vectors and comparing similarity between texts using vector algebra has been a common methodology in several applications. For example, HAL (Hyperspace Analog to Language) uses co-occurrence of word pairs in a corpus to build word vector representations (Burgess, 1998). NLS (Non-Latent Similarity) uses similarities between explicit word pairs to build word vector representations (Cai, McNamara, Louwerse, Hu, Rowe & Graesser, 2004). Latent Semantic Analysis (LSA) is the most well known example of such methods that use vectors to represent terms. Instead of using high dimensional vectors (usually, the number of words is in the neighborhood of 10^5 and the number of documents is about the same scale), LSA represents each term as a real vector (of up to 500 dimensions), and the similarity between any two texts is computed using the formula in Eq(4).

Basic Steps in LSA

The difference between LSA and other methods that we have introduced previously (Martin and Berry, this volume) is the mechanism by which the term vectors are obtained. We briefly summarize the LSA procedures for obtaining term vectors: data acquisition, singular value decomposition, and dimension reduction.

Data Acquisition: The process starts by collecting a massive amount of text data in electronic form. With such data, we prepare the $m \times n$ matrix in Eq(7),

$$\mathbf{A} = \left(f_{ij} \times G(i) \times L(i, j) \right)_{m \times n} \quad (7)$$

where m is the number of terms and n is the number of documents (usually m and n are very large, and for now, assume $n \geq m$), the value of f_{ij} is a function of the number of times term i appears in document j , $L(i, j)$ is a local weighting of term i in document j , and $G(i)$ is the global weighting for

term i . Such a weighting function is used to differentially treat terms and documents to reflect knowledge that is beyond the collection of the documents (see Martin and Berry, this volume for detail). Notice the fact that if $L(i,j)$ is multiplicative, namely $L(i,j)$ can be written as,

$$L(i, j) = k(i)l(j), \quad (8)$$

where $k(i)$ is a weight for the i^{th} term and $l(j)$ is a weight for the j^{th} document, then Eq(7) is a matrix (f_{ij}) multiplied by a diagonal matrix $\text{diag}\{k(i)G(i)\}$ on the left and another diagonal matrix $\text{diag}\{l(j)\}$ on the right, the same form as **WFA** in the context-based similarity measure.

Singular Value Decomposition (SVD): Singular value decomposition (SVD) decomposes the matrix **A** into three matrices

$$\mathbf{A} = \mathbf{U}\mathbf{\Sigma}\mathbf{V}^T \quad (9)$$

where **U** is $m \times m$ and **V** is $n \times n$ square matrices, such that $\mathbf{U}\mathbf{U}^T = \mathbf{I}$; $\mathbf{V}\mathbf{V}^T = \mathbf{I}$ (orthonormal matrices), and $\mathbf{\Sigma}$ is an $m \times n$ diagonal matrix with singular values on the diagonal. In addition, the singular values are non-negative and are ordered from largest to smallest in the diagonal of $\mathbf{\Sigma}$ (see Martin and Berry, this volume for detail of SVD).

Dimension Reduction: By removing dimensions corresponding to small singular values and keeping the dimensions corresponding to larger singular values, the representation of each term is reduced to a smaller vector with only k dimensions. The original SVD Eq(9) becomes Eq(10).

$$\mathbf{A}_k = \mathbf{U}_k \mathbf{\Sigma}_{k \times k} \mathbf{V}_k^T \quad (10)$$

The new term vectors (rows in the reduced **U** matrix, \mathbf{U}_k) are no longer orthogonal, but the advantage of this is that only the most important dimensions that correspond to larger singular values are kept. This operation is believed to remove redundant information in the matrix **A** and reduce noise from semantic information. In the LSA procedure described above, the Data

Acquisition and the Dimension Reduction parts are the most intuitive. The most mysterious part is the SVD. Why and how it works is a very deep mathematical / philosophical question and is beyond the scope of this chapter. For more details, see Martin and Berry (this volume).

Basic facts about LSA

After \mathbf{U}_k is obtained, each term has a unique k -dimensional vector representation.

Furthermore, any text containing one or more terms will also have a corresponding vector with the same number of dimensions. The vector for a text can be computed as a function of the term vectors. Text vectors are computed differently for different applications. The formula for the text vector is in the same form as Eq(3), except that \mathbf{t}_i is the i^{th} row of $\mathbf{W}\mathbf{U}_k\mathbf{\Lambda}$, where $\mathbf{W}=\text{diag}\{w_i\}$ is a diagonal matrix and w_i is the weight for term i $\mathbf{\Lambda} = \text{diag}\{\lambda_j\}$ is a diagonal matrix where λ_j is the weight of dimension j . The similarity between any two texts is calculated by the formula in Eq(4).

The procedure outlined above is relatively simple. There are several advantages to using LSA, but two of them are primary:

- 1) It picks up the word importance score from the information provided by the corpus.
- 2) It sets up semantic similarity between words. This widely extends the synonym relation between words.

In addition to the advantages, there are several key elements in LSA that are not directly obvious. These are listed below.

- a) The computation of weights $G(i)$ and $L(i, j)$ in Eq(7) is nontrivial. $G(i)$ is a measure of how important a term is in the entire collection of texts. In order to obtain $G(i)$ and $L(i, j)$, one needs to process the entire corpus first to get some kind of importance measure such as frequency of appearance. A direct consequence of this is that the entire matrix \mathbf{A} needs to be recalculated whenever some more documents are put into the corpus, because word frequencies are

changed. It presumably encodes the weighting of term i in document j and the importance of document j . Such parameters are needed during the data acquisition/encoding phase. It is very important to note that the influence of the parameters can only be evaluated after the three steps and it is very hard to set the parameters because of the massive amount of computation needed to reach the last step.

- b) Selection of the number of dimensions (k) is a challenging task. One needs to specify k before the computation. There is no intuitive way to determine the best k , other than by repeated empirical evaluations (Zha and Zhang, 1999).
- c) The computation of Eq(4) is task dependent. For example, if one only wants to compare the similarity between two texts, then Λ is an identity matrix ($\lambda_j = 1, j = 1, \dots, k$). If one wants to retrieve a document from the original corpus and obtain the closest vector in \mathbf{V} , then Λ is the inverse of the singular values from the SVD (Berry, 1992). The former similarity computation is called the term method, wherein the later computation is called the document method (see <http://lsa.colorado.edu/>).
- d) The first dimension is problematic. Because all entries of the original matrix \mathbf{A} are non-negative, the first dimension of \mathbf{U}_k always has the same sign (Hu, Cai, Franceschetti, Penumatsa, Graesser, Louwerse, McNamara & TRG, 2003) and the mean of the first dimension values is much larger than that of other dimensions. This trend is illustrated in Figure 1. As a result of this, the cosine value between any two documents, if one uses the term method, is monotonically related to number of words contained in the documents. This fact was observed by Buckley, Singhal, Mitra, and Salton (1996). Such trend is illustrated in Figure 2.

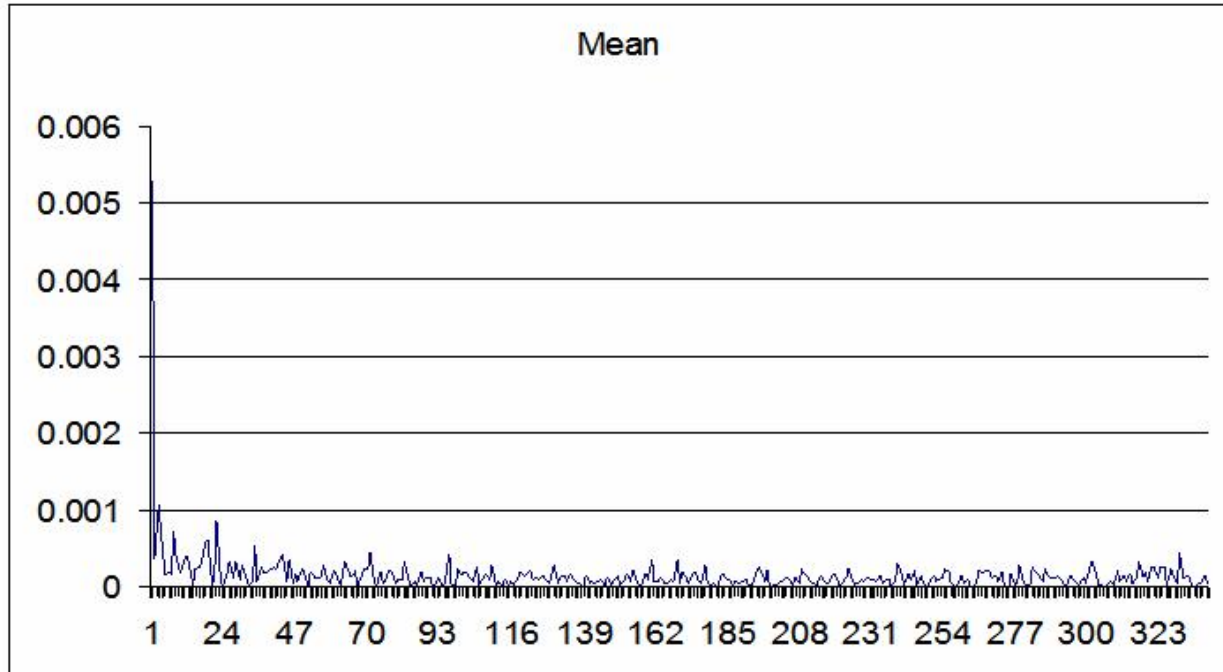

Figure 1

Doc B	Document A									
	1	2	4	8	16	32	64	128	256	512
1	0.05	0.02	0.04	0.04	0.05	0.08	0.10	0.11	0.13	0.15
2	0.04	0.02	0.02	0.03	0.05	0.08	0.08	0.10	0.13	0.14
4	0.03	0.02	0.03	0.04	0.05	0.07	0.09	0.11	0.13	0.15
8	0.05	0.03	0.03	0.04	0.05	0.08	0.11	0.13	0.16	0.17
16	0.05	0.05	0.05	0.06	0.09	0.11	0.15	0.18	0.21	0.25
32	0.08	0.06	0.06	0.06	0.11	0.15	0.19	0.24	0.28	0.31
64	0.10	0.07	0.08	0.09	0.13	0.18	0.24	0.28	0.35	0.39
128	0.11	0.08	0.09	0.11	0.15	0.21	0.29	0.34	0.41	0.45
256	0.13	0.10	0.11	0.12	0.17	0.23	0.32	0.38	0.46	0.51

Figure 2

- e) The vector representations for the terms are not fully used. Up to now, their contribution is essentially in the computation of similarities between terms. In other words, in the computation of text similarity, LSA only provides the information about “term similarity”. A little mathematics can help to make this clear. Denote the term vectors by \mathbf{t}_i ($i=1, \dots, n$), the number of occurrences of term i test 1 by a_i and in text 2 by b_i , then text 1 and text 2 are represented by vectors \mathbf{T}_1 and \mathbf{T}_2 respectively, where

$$\mathbf{T}_1=(a_1\mathbf{t}_1,a_2\mathbf{t}_2,\dots,a_n\mathbf{t}_n),$$

$$\mathbf{T}_2=(b_1\mathbf{t}_1,b_2\mathbf{t}_2,\dots,b_n\mathbf{t}_n).$$

The similarity between \mathbf{T}_1 and \mathbf{T}_2 is computed by the cosine of the angle between \mathbf{T}_1 and \mathbf{T}_2

$$\cos(\mathbf{T}_1, \mathbf{T}_2) = \frac{\mathbf{T}_1 \mathbf{T}_2^T}{\sqrt{\mathbf{T}_1 \mathbf{T}_1^T} \sqrt{\mathbf{T}_2 \mathbf{T}_2^T}} = \frac{\sum_{i=1}^n \sum_{j=1}^n a_i b_j \mathbf{t}_i \mathbf{t}_j^T}{\sqrt{\sum_{i=1}^n \sum_{j=1}^n a_i a_j \mathbf{t}_i \mathbf{t}_j^T} \sqrt{\sum_{i=1}^n \sum_{j=1}^n b_i b_j \mathbf{t}_i \mathbf{t}_j^T}}, \quad (11)$$

where $\mathbf{t}_i \mathbf{t}_j^T$ are dot products of the term vectors. When the term vectors are normalized to unit length, the products are similarities between terms. In other words, the obtained $n \times n$ matrix, $\mathbf{P} = (s_{ij})_{n \times n}$, where $s_{ij} = \mathbf{t}_i \mathbf{t}_j^T$, $i, j = 1, 2, \dots, n$ is the similarity (un-normalized) between term i and term j . Eq(11) gives a way to compute text similarities based on the term similarity matrix. However, we need an $n \times n$ matrix to save the un-normalized term similarities. The advantage of vector representation of terms here is the saving of storage space (from $n \times n$ to $n \times k$ real numbers). It may be a significant saving, when n is greater than k . One drawback is the lost of flexibility in constructing the term similarity matrix (Cai, et al. 2004).

We end this section by proving a theorem that relates LSA and weighted keyword matching (Hu, et al. 2003). This theorem will help to develop other sections of the chapter.

Theorem *Assume k equals the number of nonzero singular values, then*

1. *If $\Lambda = \Sigma_{k \times k}$, and $L(i, j)$ is multiplicative, as in Eq(8), then Eq(4) is weighted context matching.*
2. *If $\Lambda = I_{k \times k}$, then Eq(4) is weighted keyword matching.*

Based on our discussions in this section, we observed that there are some facts about LSA that is none trivial (facts d) and e), for example). In the next section, we will examine the use of LSA in several applications and point out some weaknesses of LSA.

Limitations of LSA

In order to understand the limitations that we point out here, we briefly describe two applications that use LSA. For details about these two applications, the reader may find more in other chapters in this book (see Graesser et al., this volume; McNamara, Cai, & Louwerse, this volume).

AutoTutor: AutoTutor is a natural language tutoring system that teaches conceptual physics and computer literacy via the Internet (Graesser, Wiemer-Hastings, Wiemer-Hastings,, Harter, Person, & TRG. 2000). One challenge for this system is to assess the quality of the student's response to the system. LSA cosine match is used to compare the student's response with the expected answers stored in a curriculum script. The values are used to help AutoTutor provide appropriate feedback for the student.

Coh-Metrix: Coh-Metrix is a web tool that analyzes texts and provides up to 250 measures of cohesion and language characteristics (Graesser, McNamara, Louwerse, & Cai, 2004). Some of the cohesion measures consist of density scores for particular types of cohesion links between text constituents, such as paragraphs, sentences, clauses, or even words. LSA is used in this system to assess the conceptual relatedness of constituents (i.e., the more related, the more cohesive) and to assess co-referential cohesion (i.e., the extent to which content words refer to other constituents in the text).

The Statistical Nature of LSA values

As we have pointed out previously, the first dimension of all the term vectors have the same sign. This indicates that if one uses the term method to compute the similarity, the value computed by Eq(4) is directly influenced by the number of words in the texts. A simple simulation shows that the cosine value between two texts monotonically increases as a function of the number of terms in the two documents (see Figure 2). This property of the term method makes it very hard

to interpret text similarity measures without considering the sizes of the texts (Hu, Cai et al, 2003). In the case of AutoTutor, students' contributions are compared with stored expectations. AutoTutor selects a fixed value between 0 and 1. If the cosine match between students' contribution and the stored expectation exceed such value, AutoTutor assumes the expectation is covered. The fixed value for this purpose is called a threshold. The issue here is how to set the threshold. The threshold should be a function of the number of terms contained in the student's contribution and the individual expectations. This limitation is not relevant in the case where similarity is computed using the document method, where the influence of the first dimension is minimized, nor in the case where the similarity is used for information retrieval, where only the ordinal property of the similarity value is used (Graesser et al., 2004).

The use of detailed dimensional information

The procedure outlined in the previous section has demonstrated that the original \mathbf{U} matrix from the SVD and the truncated \mathbf{U}_k are substantially influenced by the information contained in the original corpus. We further observed that even with the remaining k dimensions, LSA only has limited use. In fact, all the remaining dimensions are used only to obtain dot-products between terms, as it was shown in Eq(11). In the next few sections, we demonstrate that the vector representations of terms and documents contain more information. The information contained in the dimensions can be further used to extend the usefulness of LSA.

Extending LSA

Two observed weaknesses of LSA motivated us to propose two extensions of LSA that address the observations. One extension is to use the statistical characteristics to reduce the text size effect in the LSA similarity computation. The other extension is to make more use of the dimensional information contained in the vector representation.

Statistical Characteristics of LSA

LSA was originally used as a tool for information retrieval (IR) (Graesser, Hu, et al., 2004) where recall was more emphasized than precision in most of the applications. In IR, the influence of the first dimension is not as strong as in similarity measure. This is because (1) the query vector is computed from $\mathbf{WU}_k\mathbf{\Lambda}$ where $\mathbf{\Lambda}=\mathbf{\Sigma}^{-1}$ so the first dimension was weighted inversely by the largest singular value and (2) the document vector is from \mathbf{V}_k where the rows are normalized before they are truncated. Furthermore, only the ordinal nature of the cosine value is used in IR because the main goal is to fetch the most relevant document to the query. As a consequence, consideration of the statistical nature of the cosine values is not necessary. In the case of the similarity measure, however, the query vector is computed from \mathbf{WU}_k so the first dimension is always the most influential. Furthermore, in some applications, such as AutoTutor, the cosine values are compared with a threshold. As indicated in Figure 2 and proven by Hu et al. (2003), the cosine values are always a monotonic function of the texts' size. For example, a cosine value of 0.2 between two terms may indicate a high degree of similarity but may not indicate any similarity at all between texts with over 200 terms. This analysis suggests that when using LSA cosine values for the measures of similarity between texts, one needs to consider the sizes of the texts (Buckley et al,1996; Hu, Cai et al 2003).

Given the weighted term matrix \mathbf{WU}_k , one can always obtain some basic statistical information such as the average cosine $\mu(n_1, n_2)$ and the standard deviation $\sigma(n_1, n_2)$ of any two texts with n_1 and n_2 terms respectively. Furthermore, if the distribution of all possible cosine values between two texts is normally distributed, one can obtain the relative cosine values between two texts using the following simple formula

$$S(\mathbf{T}_1, \mathbf{T}_2) = \frac{\cos(\mathbf{T}_1, \mathbf{T}_2) - \mu(n_1, n_2)}{\sigma(n_1, n_2)}, \quad (12)$$

where n_1 and n_2 are the number of terms in \mathbf{T}_1 and \mathbf{T}_2 respectively.

Adaptive Methods of LSA

As we have pointed out in the previous section, the vector representation of terms in LSA space has been used only to produce a numerical value (vector dot product) between two terms. We argue that there are several other ways of using the dimensional information contained in the vector representation. We call this approach the "adaptive method" of LSA. For the purpose of later sections, we briefly review a few concepts in linear algebra.

Some basic concept in linear algebra

Linear Combination: A vector \mathbf{b} is a **linear combination** of the vectors $\mathbf{v}_1, \mathbf{v}_2, \dots, \mathbf{v}_n$, if $\mathbf{b} = c_1\mathbf{v}_1 + c_2\mathbf{v}_2 + \dots + c_n\mathbf{v}_n$, where c_1, c_2, \dots, c_n are scalars.

Span: Suppose $\mathbf{v}_1, \mathbf{v}_2, \dots, \mathbf{v}_n$ are vectors in a vector space V . These vectors are said to **span** V if every vector \mathbf{v} in V can be expressed as a linear combination of these vectors.

Linear Dependence: A set of vectors $\mathbf{v}_1, \mathbf{v}_2, \dots, \mathbf{v}_n$ are **linearly dependent** if it is possible to express one of the vectors as the others; that is, for some k ,

$$\mathbf{v}_k = \sum_{\substack{1 \leq i \leq n \\ i \neq k}} a_i \mathbf{v}_i$$

Linear Independence: A set of vectors $\mathbf{v}_1, \mathbf{v}_2, \dots, \mathbf{v}_n$ are **linearly independent** if it is impossible to express any one of the vectors as the others.

Basis: A set of vectors $\mathbf{v}_1, \mathbf{v}_2, \dots, \mathbf{v}_n$ in V is a **basis** for V if the vectors are linearly independent and span V .

Standard Basis: The set of vectors $\mathbf{e}_1, \mathbf{e}_2, \dots, \mathbf{e}_n$ where

$$\begin{aligned}
e_1 &= (1, 0, 0, \dots, 0) \\
e_2 &= (0, 1, 0, \dots, 0) \\
e_3 &= (0, 0, 1, \dots, 0) \\
&\vdots \\
e_n &= (0, 0, 0, \dots, 1)
\end{aligned} \tag{13}$$

is called the standard basis for \mathbf{R}^n .

Dimension: A vector space V has a **dimension** n if V has a basis consisting of n vectors.

The dimension of V is denoted by $\dim(V)$.

Representation: Since every vector can be represented uniquely by the *base*, meaning and interpretation of any vector can only be understood through the meaning and interpretation of the vectors contained in the *base*. This is the key notion behind the current claims. LSA vector is “latent” only because the dimensions are implicit (latent).

Adapting to Perspective

The typical feature of LSA is that the dimensions are latent. That means there are no explicit interpretations for the dimensions. Even though this is a fact about LSA, researchers frequently try to find some more information from the dimensions and interpret the values. For example, we observed some special properties of the first dimension (Hu et al., 2003). In this section, we explore two questions that are potentially relevant. First, can we make the latent dimensions explicit? Second, can we find explicit relations between words and between documents? From some initial derivations, we provide a mathematical solution. The basic idea is to represent information on some explicit dimensions. To do so, we simply need to (1) find a new base with meaningful dimensions and (2) transform the entire LSA vector space to the new base.

To illustrate, we consider a very simple example where only two dimensions are involved. If a vector \mathbf{S} is in an arbitrary coordinate system $\mathbf{U}\mathbf{X}\mathbf{V}$, then \mathbf{S} (with coordinates (u,v)) cannot be easily interpreted without an explicit interpretation of \mathbf{U} and \mathbf{V} . However, if a new system $\mathbf{X}\mathbf{X}\mathbf{Y}$ is

introduced where \mathbf{X} is the horizontal axis and \mathbf{Y} is vertical axis, \mathbf{S} can be interpreted easily, due to the obvious interpretation of \mathbf{X} and \mathbf{Y} (see Fig. 3).

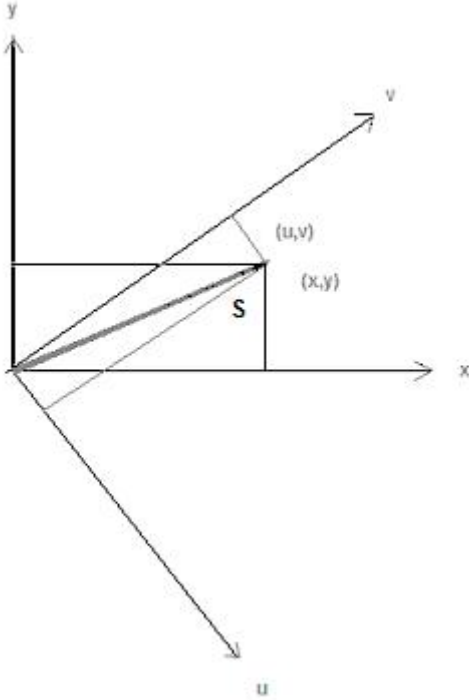

Figure 3

To generalize the above intuitive example, we derive a general algorithm that can be used in LSA space with k dimensions. Consider the LSA term matrix $\mathbf{H}_{m \times k} = \mathbf{WU}_k \mathbf{\Lambda}$ with m term vectors. Furthermore, we may assume $\mathbf{b}_1, \mathbf{b}_2, \dots, \mathbf{b}_k$ are any set of independent vectors that serve as a base of the space. For example, the base could be k words that represent k distinct categories, or a centroid of some categories that can be interpreted. From linear algebra, for any row in $\mathbf{H}_{m \times k}$, $\mathbf{h}_i = (h_{i1}, h_{i2}, \dots, h_{ik})$ there is a unique nonzero vector $(e_{i1}, e_{i2}, \dots, e_{ik})$, such that

$$\mathbf{h}_i = \sum_{j=1}^k e_{ij} \mathbf{b}_j. \quad (14)$$

In this case, $\mathbf{e}_i = (e_{i1}, \dots, e_{ik})$ is the new representation under new base $\mathbf{B}=(\mathbf{b}_1, \mathbf{b}_2, \dots, \mathbf{b}_k)$. To illustrate, suppose in the original LSA space, two terms are represented by two rows in $\mathbf{H}_{m \times k}$, $\mathbf{h}_s =$

$(h_{s1}, h_{s2}, \dots, h_{sk})$ and $\mathbf{h}_t = (h_{t1}, h_{t2}, \dots, h_{tk})$. There exist unique $\mathbf{c}_s = (c_{s1}, c_{s2}, \dots, c_{sk})$ and $\mathbf{c}_t = (c_{t1}, c_{t2}, \dots, c_{tk})$, for $\mathbf{h}_s = \mathbf{c}_s \mathbf{B}^T$ and $\mathbf{h}_t = \mathbf{c}_t \mathbf{B}^T$, respectively, where $\mathbf{c}_s \mathbf{B}^T$ and $\mathbf{c}_t \mathbf{B}^T$ are inner products of vectors. The cosine in the original space is

$$\frac{\mathbf{h}_s \mathbf{h}_t^T}{\|\mathbf{h}_s\| \|\mathbf{h}_t\|} = \frac{(h_{s1}, h_{s2}, \dots, h_{sk})(h_{t1}, h_{t2}, \dots, h_{tk})^T}{\|\mathbf{h}_s\| \|\mathbf{h}_t\|} = \frac{\mathbf{c}_s (\mathbf{B}^T \mathbf{B}) \mathbf{c}_t^T}{\|\mathbf{h}_s\| \|\mathbf{h}_t\|},$$

where $\|\bullet\|$ is the length of a vector. On the other hand, since $\mathbf{c}_s = \mathbf{h}_s (\mathbf{B}^T)^{-1}$ and $\mathbf{c}_t = \mathbf{h}_t (\mathbf{B}^T)^{-1}$, the cosine under the new base can be obtained by

$$\frac{\mathbf{c}_s \mathbf{c}_t^T}{\|\mathbf{c}_s\| \|\mathbf{c}_t\|} = \frac{(c_{s1}, c_{s2}, \dots, c_{sk})(c_{t1}, c_{t2}, \dots, c_{tk})^T}{\|\mathbf{c}_s\| \|\mathbf{c}_t\|} = \frac{\mathbf{h}_s ((\mathbf{B}^T)^{-1} (\mathbf{B})^{-1}) \mathbf{h}_t^T}{\|\mathbf{c}_s\| \|\mathbf{c}_t\|}.$$

The interesting question is whether we can find a meaningful base. The answer is yes and the construction of such bases can be very simple. For example, we can choose k key terms that we think are most relevant to our task. If the corresponding term vectors are linearly independent, then these k term vectors form a base. Then, any term in the space can be linearly expressed by these selected k term vectors. By definition, these k term vectors form a base of the k -dimensional space. In the above description, we have used $(\mathbf{b}_1, \mathbf{b}_2, \dots, \mathbf{b}_k)$ where k is the rank of $\mathbf{H}_{m \times k} = \mathbf{WU}_k \mathbf{\Lambda}$.

In fact, from the derivation above, we can prove that it is not necessary to specify all k vectors for the base. One could simply specify a few meaningful vectors $(\mathbf{b}_1, \mathbf{b}_2, \dots, \mathbf{b}_{k_0})$ and select $(k - k_0)$ vectors from the old base from Eq(13).

Adapting to context

In AutoTutor, every input from student is compared to several expectations. LSA is used to decide whether each of the expectations is covered. It turned out that some of the expectations have similar LSA vectors. When this occurs, it would be ideal to adjust AutoTutor so that it can detect small differences between the expectations. The process of adjusting LSA to this task is

outlined below. We call this the method of “adapting to context.”

Before we derive the formal method, consider the following keyword match example to help understand our basic claims. Assume that the two target expectations are A : "The horizontal speed is constant for the moving body" and B : "The vertical speed is zero for the moving body". Assume that the student's input is C : "The moving body will move forward with constant speed.". To distinguish A from B , there are some common words (*the, is, for, the, moving, body*) shared by A and B ; they will not add much value in discriminating the two alternative expectations. In this case, one can either include common words or exclude common words. When common words are included, the similarity between A and C is 0.556 whereas the similarity between B and C is 0.444. When common words are excluded, the similarity between A and C is 0.258 whereas the similarity between B and C is 0.

Table 1 is about here

As shown from this example, one might prefer the exclusion method so that C is relatively more similar to A than B . In essence, the differences between A and B would be magnified and this would be reflected in the similarity between C and A versus B (See Table 1). There needs to be a method to implement this context-sensitive magnification to LSA, where each expectation is represented as an LSA vector. Assume the two target expectations have vectors \mathbf{A} and \mathbf{B} , and that the student's input is vector \mathbf{C} .

$$\begin{aligned}\mathbf{A} &= (a_1, a_2, \dots, a_k) \\ \mathbf{B} &= (b_1, b_2, \dots, b_k) , \\ \mathbf{C} &= (c_1, c_2, \dots, c_k)\end{aligned}$$

Further assume that n_A , n_B and n_C are the number of words in A , B and C , respectively, and that we have identified statistical properties of the LSA space. That is, for each column of $\mathbf{WU}_k \mathbf{A}$, such as column x , there is the mean μ_x and standard deviation σ_x , $x = 1, 2, \dots, k$. Given these statistics

and the number of words in A , B , and C , the expected values and variability (standard deviation) of the x^{th} elements of \mathbf{A} , \mathbf{B} , and \mathbf{C} are $(n_A \mu_x, \sqrt{n_A} \sigma_x)$, $(n_B \mu_x, \sqrt{n_B} \sigma_x)$, and $(n_C \mu_x, \sqrt{n_C} \sigma_x)$. With these values computed, we can then decide the difference between \mathbf{A} and \mathbf{B} by comparing quantities computed based on Eq(15) for all $x = 1, \dots, k$.

$$\frac{n_A \mu_x - n_B \mu_x}{\sqrt{n_A \sigma_x^2 + n_B \sigma_x^2}} = z_x \quad (15)$$

The final comparison between \mathbf{A} and \mathbf{B} versus \mathbf{B} and \mathbf{C} is computed in Eq(16),

$$\begin{cases} S'(\mathbf{A}, \mathbf{C}) = \frac{\sum_{x=1}^k f(z_x) a_x c_x}{\sqrt{\sum_{x=1}^k f(z_x) a_x^2} \sqrt{\sum_{x=1}^k f(z_x) c_x^2}} \\ S'(\mathbf{B}, \mathbf{C}) = \frac{\sum_{x=1}^k f(z_x) b_x c_x}{\sqrt{\sum_{x=1}^k f(z_x) b_x^2} \sqrt{\sum_{x=1}^k f(z_x) c_x^2}} \end{cases}, \quad (16)$$

where $f(z)$ is a function such that $f(z') \geq f(z'')$ if $z' > z''$. The simplest case for the function $f(z)$ is the function captured in Eq(17).

$$f(z) = \begin{cases} 1 & z > \delta \\ 0 & z \leq \delta \end{cases} \quad (17)$$

The function Eq(17) was used in the simulation that we describe next.

Simulation

We explored the above analysis by a simple simulation (see Fig. 4 as an illustration) where \mathbf{A} , \mathbf{B} , and \mathbf{C} are generated random vectors with 300 dimensions. In the simulation, two set of vectors that are “similar” at dimension x if $z_x=0$. \mathbf{A} and \mathbf{B} are similar for 150 of the dimensions while \mathbf{A} and \mathbf{C} are similar for those 37 of the 150 dimensions for which \mathbf{A} and \mathbf{B} are different. Thus, similarity is based on those dimensions that differentiate \mathbf{A} and \mathbf{B} , not all dimensions.

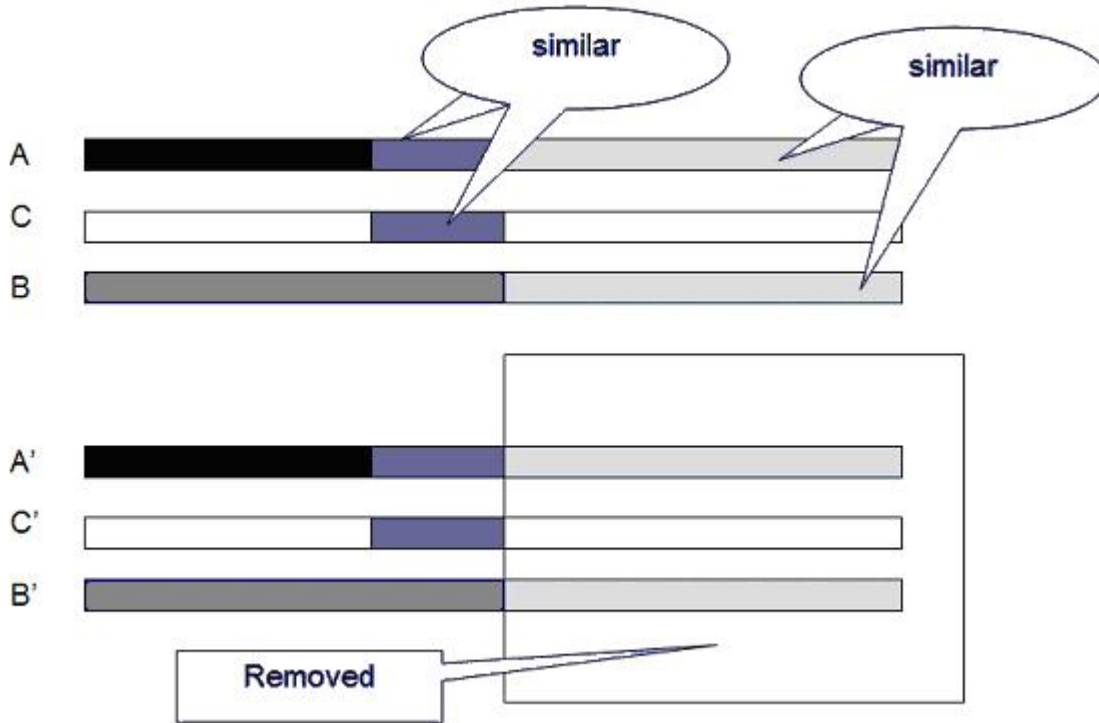

Figure 4

We obtained all simulated values of Eq(16), both with and without using the weighting function Eq(17). We observed the difference between $S'(\mathbf{A}, \mathbf{C})$ and $S'(\mathbf{B}, \mathbf{C})$ is larger with Eq(17) (upper picture of Fig. 5, $d' = 3.05$) than the case in which Eq(17) was not used (lower picture of Fig. 5, $d' = 2.07$).

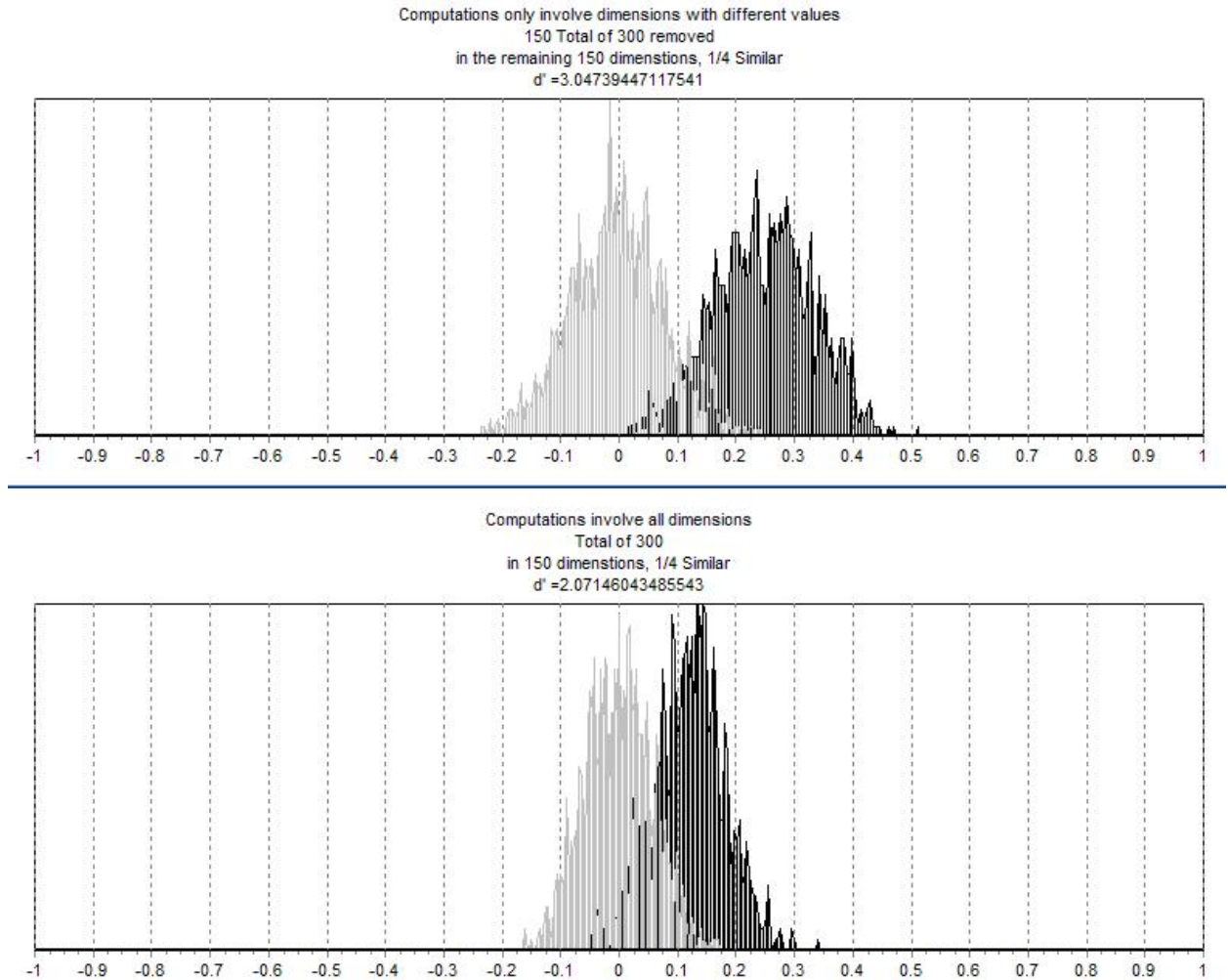

Figure 5

From the above analysis and simulation, we argue that when using LSA similarity to select one option from multiple alternatives (such as using **C** to select one of **A** and **B**, as in the example and simulation), considering detailed dimensional information will help the selection. In this method, context constrained and narrows down the alternatives at the level of detailed dimensions. We call this the method of "adapting to context."

Adapting to dialog history

This is a method especially appropriate in situations where LSA is used to evaluate sequence of contributions. Consider AutoTutor when the tutor's goal is to help the student produce

an answer to a question. The student typically gives one piece of information at a time. To furnish a complete answer to a question, the student needs to produce multiple pieces of information. In order for the tutor to be helpful and effective, the tutor needs to evaluate every contribution of the student and to help the student every time a contribution is made. We assume that AutoTutor is suppose to give feedback based on student's contribution towards the answer and that AutoTutor is suppose to give four different context-sensitive feedbacks at every contribution:

Table 2 is about here

Similar to the analysis of the previous method, we first consider what AutoTutor would do if the evaluation method were keyword matching. For an ordered sequence of statements, S_1, S_2, \dots, S_N and a target statement S_0 , for any given i ($2 \leq i \leq n$), one can decompose S_i into the four different bags of words, as specified below:

- Words that overlap with words in S_0 (relevant)
 - Appeared in $S_1, S_2 \dots, S_{i-1}$ (old)
 - Never appeared in $S_1, S_2 \dots, S_{i-1}$ (new)
- Words that do not overlap with words in S_0 (irrelevant)
 - Appeared in $S_1, S_2 \dots, S_{i-1}$ (old)
 - Never appeared in $S_1, S_2 \dots, S_{i-1}$ (new)

Having established relations between keyword match and LSA in the previous section, the similar decomposition can be achieved in the present case. Denote $\mathbf{s}_i = s_i \mathbf{WU}_k$, $I = 0, 1, \dots, n$. For an ordered sequence of statements, $\mathbf{s}_1, \mathbf{s}_2, \dots, \mathbf{s}_n$ and a target statement \mathbf{s}_0 , for any given i ($2 \leq i \leq n$), one can decompose \mathbf{S}_i into four different vectors:

- 1) Vector that is parallel to \mathbf{s}_0 (relevant)
 - i) Parallel to the spanned space of $\mathbf{s}_1, \mathbf{s}_2, \dots, \mathbf{s}_{i-1}$ (old)

- ii) Perpendicular to the spanned space of $\mathbf{s}_1, \mathbf{s}_2, \dots, \mathbf{s}_{i-1}$ (new)
- 2) Vector that is perpendicular to \mathbf{s}_0 (irrelevant)
 - i) Parallel to the spanned space of $\mathbf{s}_1, \mathbf{s}_2, \dots, \mathbf{s}_{i-1}$ (old)
 - ii) Perpendicular to the spanned space of $\mathbf{s}_1, \mathbf{s}_2, \dots, \mathbf{s}_{i-1}$ (new)

AutoTutor would ideally provide feedback based on the rate of change on each of the four components. For example, AutoTutor would provide positive feedback if each input from the student contains more *new* and *relevant* information. Ideally, a student would contribute a sequence of statements towards the answer. In AutoTutor, feedback at step i is based on how much student has contributed to the *coverage* of the expected answer until step i . To compute the coverage score, we need to introduce some notations. Let $proj(\mathbf{s}, \mathbf{P})$ denote the projection of vector \mathbf{s} in the subspace \mathbf{P} and $\mathbf{S}_i = \text{span}\{\mathbf{s}_1, \mathbf{s}_2, \dots, \mathbf{s}_{i-1}\}$, For any given i ($2 \leq i \leq n$), the four components above can be specified in Eq(18).

$$\begin{aligned}
 \text{relevant, old} & : u_i = proj(proj(\mathbf{s}_i, \text{span}\{\mathbf{s}_0\}), \mathbf{S}_i) \\
 \text{relevant, new} & : v_i = proj(proj(\mathbf{s}_i, \text{span}\{\mathbf{s}_0\}), \mathbf{S}_i^\perp) \\
 \text{irrelevant, old} & : x_i = proj(proj(\mathbf{s}_i, (\text{span}\{\mathbf{s}_0\})^\perp), \mathbf{S}_i) \\
 \text{irrelevant, new} & : y_i = proj(proj(\mathbf{s}_i, (\text{span}\{\mathbf{s}_0\})^\perp), \mathbf{S}_i^\perp)
 \end{aligned} \tag{18}$$

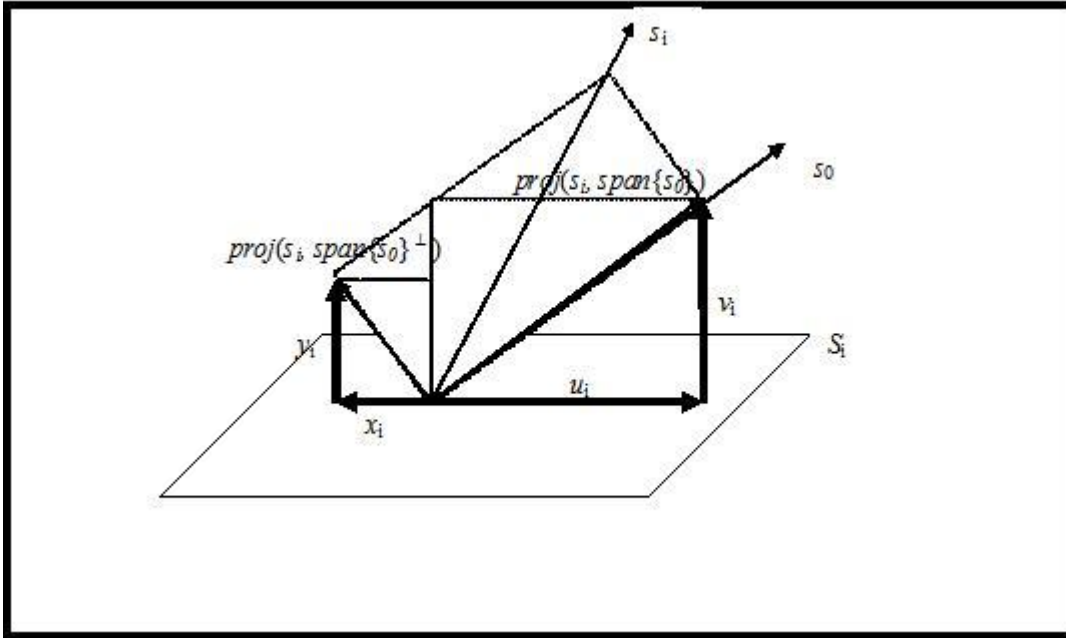

Figure 6

The accumulation of "relevant, new" information is called coverage. To compute the coverage score, we use an iterative procedure. If c_i is the coverage score for space S_i , then the new coverage score c_{i+1} by the space S_{i+1} is expressed in Eq(19).

$$c_{i+1} = \sqrt{c_i^2 + \frac{\|v_i\|^2}{\|s_0\|^2}} \quad (19)$$

We illustrate the above arguments by applying to the following example from AutoTutor.

Question: *Suppose a runner is running in a straight line at a constant speed and throws a pumpkin straight up. Where will the pumpkin land? Explain why.*

Expectation: *The pumpkin will land in the runner's hands.*

Student's contribution:

- 1) *I think, correct me if I am wrong, it will not land before or behind the guy.*
- 2) *The reason is clear; they have the same horizontal speed.*
- 3) *The pumpkin will land in the runner's hand.*

4) *Did I say anything wrong?*

5) *Come on, I thought I have said that!*

We use old LSA (with threshold 0.8) and adaptive methods to compute coverage of the student's contribution at each step (see Table 1). We observed that even when the student produced a perfect answer (such as answer 3), the old LSA method failed to detect it (the cosine match was still less than the threshold, due to the fact that contributions 1 and 2 are evaluated with 3 together).

Furthermore, the last two of the contributions have very little contribution to the coverage of the expectation, so the old LSA method decreased, as expected. However, when we used the adapting to context method described above, we observed the monotonic increase in coverage scores and a perfect match score when the student provided the perfect answer (see Table 3).

Table 3 is about here

The basic idea in this method is to consider the span of the vectors prior to current vector. Hence, the method is called the "Span Method". As we can see from the above derivation and example, this method makes use of the dialog history and the dimensional information of the vector representation. One could imagine that Tutor's feedback could be based on other components also. For example, when the student provides *old* and *irrelevant* information, AutoTutor may detect that persistent misconceptions are driving the answers. AutoTutor's feedback is largely determined by the values of u_i, v_i, x_i, y_i at any step i . The overall performance is computed as an accumulation score, as in the case of Eq(19).

Conclusions

In this chapter, we have pointed out two limitations of LSA: 1) limited use of statistical information of LSA space and 2) limited use of dimensional information in the vector representation of the terms. Based on these observations, we have proposed a few extensions.

These include a modified cosine match (as shown in Eq(12)) as similarity measures and adaptive methods that intelligently select dimensional information of the vector representations. We have concentrated large portion of the chapter developing the adaptive methods. We have proposed three adaptive methods: 1) adapting to perspective, 2) adapting to context, and 3) adapting to dialog history. All three adaptive methods are developed in the context of the application of AutoTutor with LSA cosine match being used as similarity measure. In this paper, we primarily concentrated on mathematical derivations and explained the extensions at the conceptual level with simple simulations. The next step is to implement the extensions in real applications.

Acknowledgements

This research was supported by grants from the Institute for Education Sciences (IES R3056020018-02), the National Science Foundation (SBR 9720314, REC 0106965, REC 0126265, ITR 0325428), and the DoD Multidisciplinary University Research Initiative (MURI) administered by ONR under grant N00014-00-1-0600. . The Tutoring Research Group (TRG) is an interdisciplinary research team comprised of approximately 35 researchers from psychology, computer science, physics, and education (visit <http://www.autotutor.org>). Any opinions, findings, and conclusions or recommendations expressed in this material are those of the authors and do not necessarily reflect the views of IES, NSF, DoD, or ONR.

References

- Berry, M. W. (1992). Large scale singular value computations. *International Journal of Supercomputer Applications* 6(1), 13-49.
- Buckley, C., Singhal, A., Mitra, M., and Salton, G. (1996). New Retrieval Approaches Using SMART: TREC 4. *In Proceedings of the Fourth Text Retrieval Conference, NIST Special Publication 500-236*, 25-48, 1996.
- Burgess, C. (1998). From simple associations to the building blocks of language: Modeling meaning in memory with the HAL model. *Behavior Research Methods, Instruments, & Computers*, 30, 188-198
- Cai, Z., McNamara, D.S., Louwerse, M.M., Hu, X., Rowe, M.P., & Graesser, A.C. (2004). NLS: A non-latent similarity algorithm. In K.D. Forbus, D. Gentner, T. Regier (Eds.), *Proceedings of the Twenty-Sixth Annual Conference of the Cognitive Science Society* (pp. 180-185). Mahwah, NJ: Erlbaum.
- Coltheart, M. (1981). The MRC Psycholinguistic Database. *Quarterly Journal of Experimental Psychology*, 33, 497-505
- Deerwester, S., Dumais, S. T., Furnas, G. W., Landauer, T. K., & Harshman, R. (1990). Indexing By Latent Semantic Analysis. *Journal of the American Society for Information Science*, 41, 391-407.
- Graesser, A.C., McNamara, D.S., Louwerse, M.M., & Cai, Z. (2004). Coh-Metrix: Analysis of text on cohesion and language. *Behavior Research Methods, Instruments, and Computers*, 36, 193-202.

- Graesser, A. C., Hu, X., Person, P., Jackson, T., & Toth, J (2004). Modules and information retrieval facilities of the Human Use Regulatory Affairs Advisor (HURAA). *International Journal on eLearning, October-November, 29-39.*
- Graesser, A., Wiemer-Hastings, P., Wiemer-Hastings, K., Harter, D., Person, N., & the Tutoring Research Group. (2000). Using latent semantic analysis to evaluate the contributions of students in AutoTutor. *Interactive Learning Environments, 8, 149-169.*
- Graesser, A., Penumatsa, P., Ventura, M., Cai, Z., & Hu, X. (in press). Using LSA in AutoTutor: learning through mixed-initiative dialogue in natural language. In T. Landauer, D.S., McNamara, S. Dennis, & W. Kintsch (Eds.), *LSA: A Road to Meaning*. Mahwah, NJ: Erlbaum.
- Hu, X., Cai, Z., Louwerse, M., Olney, A., Penumatsa, P., Graesser, A.C., & TRG (2003). A revised algorithm for Latent Semantic Analysis. *Proceedings of the 2003 International Joint Conference on Artificial Intelligence* (pp. 1489-1491).
- Hu, X., Cai, Z., Franceschetti, D., Penumatsa, P., Graesser, A.C., Louwerse, M.M., McNamara, D.S., & TRG (2003). LSA: The first dimension and dimensional weighting. In R. Alterman and D. Hirsh (Eds.), *Proceedings of the 25rd Annual Conference of the Cognitive Science Society* (pp. 1-6). Boston, MA: Cognitive Science Society.
- Landauer, T.K., & Dumais, S.T. (1997). A solution to Plato's problem: The latent semantic analysis theory of acquisition, induction, and representation of knowledge. *Psychological Review, 104, 211-240.*
- McNamara, D.S., Kintsch, E., Songer, N.B., & Kintsch, W. (1996). Are good texts always better? Text coherence, background knowledge, and levels of understanding in learning from text. *Cognition and Instruction, 14, 1-43.*

McNamara, D. S., Cai, Z., & Louwerse, M. M. (in press). Comparing latent and non-latent measures of cohesion. In T. Landauer, D.S., McNamara, S. Dennis, & W. Kintsch (Eds.), *LSA: A Road to Meaning*. Mahwah, NJ: Erlbaum.

Miller, G. A. "WordNet: a dictionary browser." In: *Proceedings of the First International Conference on Information in Data*, University of Waterloo, Waterloo, 1985.

Zha, H. and Zhang, Z,(1999). Matrices with Low-Rank-Plus-Shift Structure: Partial SVD and Latent Semantic Indexing. *SIAM Journal on Matrix Analysis and Applications*. 21:2:522-536.

Table 1.

Sentences A: "The horizontal speed is constant for the moving body", B: "The vertical speed is zero for the moving body", and C: "The moving body will move forward with constant speed."

Using two methods of keyword matching. The common words in A and B are "the", "speed", "is", "for", "moving", and "body". By removing the common words from A and B, then resulting A, B, and C are three sets of words: A: "horizontal", "constant", B: "vertical", "zero", and C: "will", "move", "forward", "with", "constant".

	Remove common words	Keep common words
A vs. C	0.258	0.556
B vs. C	0.000	0.444

Table 2.

A sequence of contributions from a student. In the case of keyword matching, treating each sentence as a collection of words, this collection of words can be classified into four different types, based on what is the answer key and all previous contributions.

	relevant	irrelevant
New	++	-
Old	+	--

Table 3.

Old LSA cosine value is the cosine match between all prior contributions and the answer key (expectation). This is the reason for the observed decreasing cosine values in the second column.

New & relevant is computed by the SPAN method in Eq(18). The *coverage* is computed by Eq(19).

	Old LSA Cosine value	New & Relevant	Coverage
1	0.431	0.431	0.431
2	0.430	0.175	0.466
3	0.751	0.885	1.0
4	0.713	0.000	1.0
5	0.667	0.000	1.0

Figure Captions

Figure 1: First dimension always has the same sign and its mean is larger than all other dimensions.

Figure 2. Cosine matches of two documents (i.e., Doc A and B) is a monotonic function of the document size (number of words in each of the two documents).

Figure 3. Vector (u,v) in an arbitrary system cannot be interpreted due to the arbitrariness of the coordinates system U and V. However, it can be interpreted if a new system (coordinates system X and Y) is used. The vector (x,y) can be obtained from the relations between the two systems, namely, U-V coordinates system and X-Y coordinates system.

Figure 4. This is an illustration of the simulation. Vectors A, B, and C are generated base on the following rule: A and B are similar 50% ; A and C are similar 25% among the dimensions where A and B are different. In the first simulation, all dimensions are used in the simulation. In the second simulation, the dimensions that A and B are similar are removed.

Figure 5. Darker distribution is the cosine between A and C, and lighter distribution is the cosine between B and C. The difference between the two distribution is $d'=2.07$ for the case where all dimensions are used and $d'=3.047$ when the common dimensions are removed.

Figure 6. A vector s_i is decomposed into components in the direction of the target vector s_0 and its perpendicular direction. The components are further decomposed in the direction of the i^{th} span S_i and its perpendicular direction.

Figure 1.

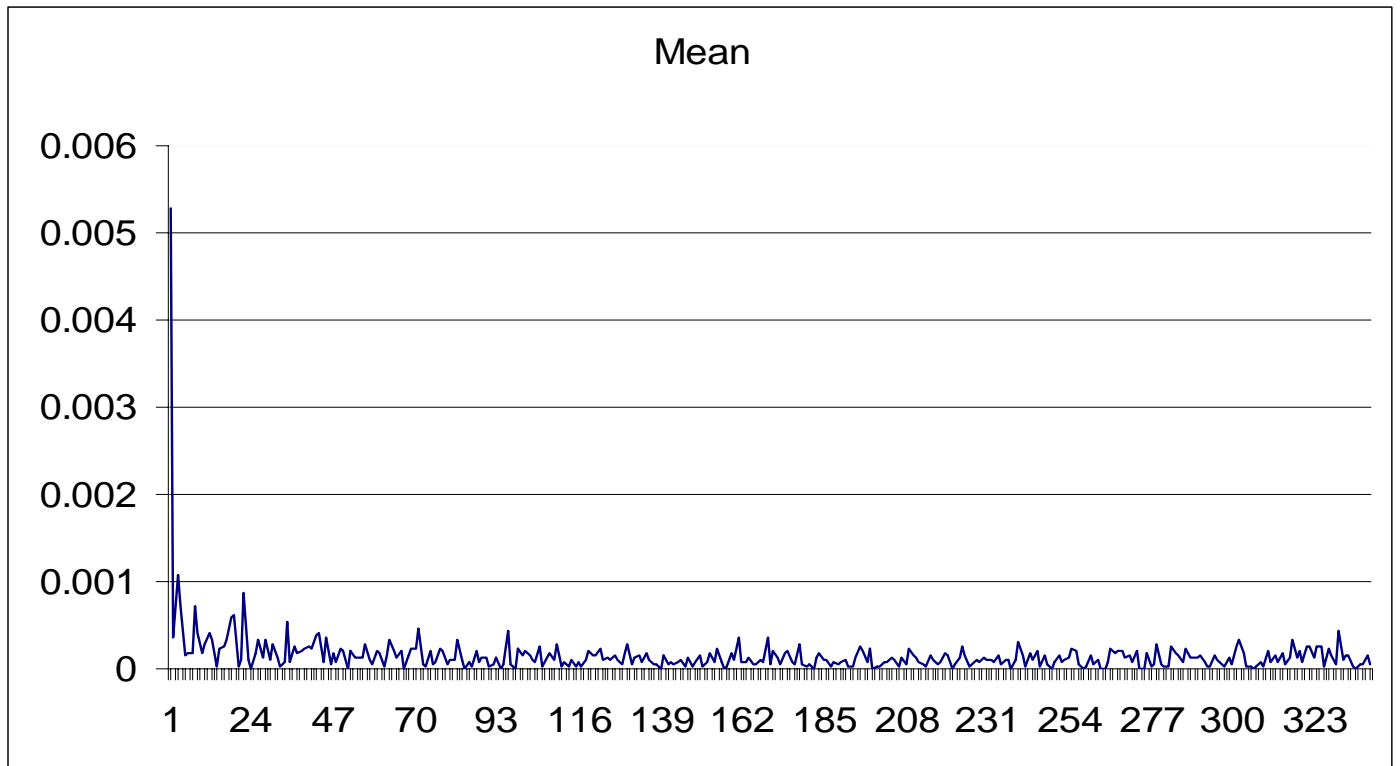

Figure 2.

Doc B	Document A									
	1	2	4	8	16	32	64	128	256	512
1	0.05	0.02	0.04	0.04	0.05	0.08	0.10	0.11	0.13	0.15
2	0.04	0.02	0.02	0.03	0.05	0.08	0.08	0.10	0.13	0.14
4	0.03	0.02	0.03	0.04	0.05	0.07	0.09	0.11	0.13	0.15
8	0.05	0.03	0.03	0.04	0.05	0.08	0.11	0.13	0.16	0.17
16	0.05	0.05	0.05	0.06	0.09	0.11	0.15	0.18	0.21	0.25
32	0.08	0.06	0.06	0.06	0.11	0.15	0.19	0.24	0.28	0.31
64	0.10	0.07	0.08	0.09	0.13	0.18	0.24	0.28	0.35	0.39
128	0.11	0.08	0.09	0.11	0.15	0.21	0.29	0.34	0.41	0.45
256	0.13	0.10	0.11	0.12	0.17	0.23	0.32	0.38	0.46	0.51

Figure 3

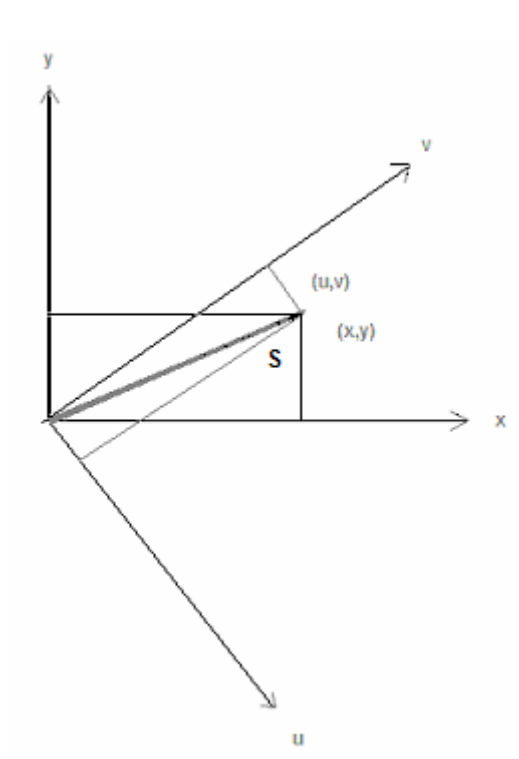

Figure 4

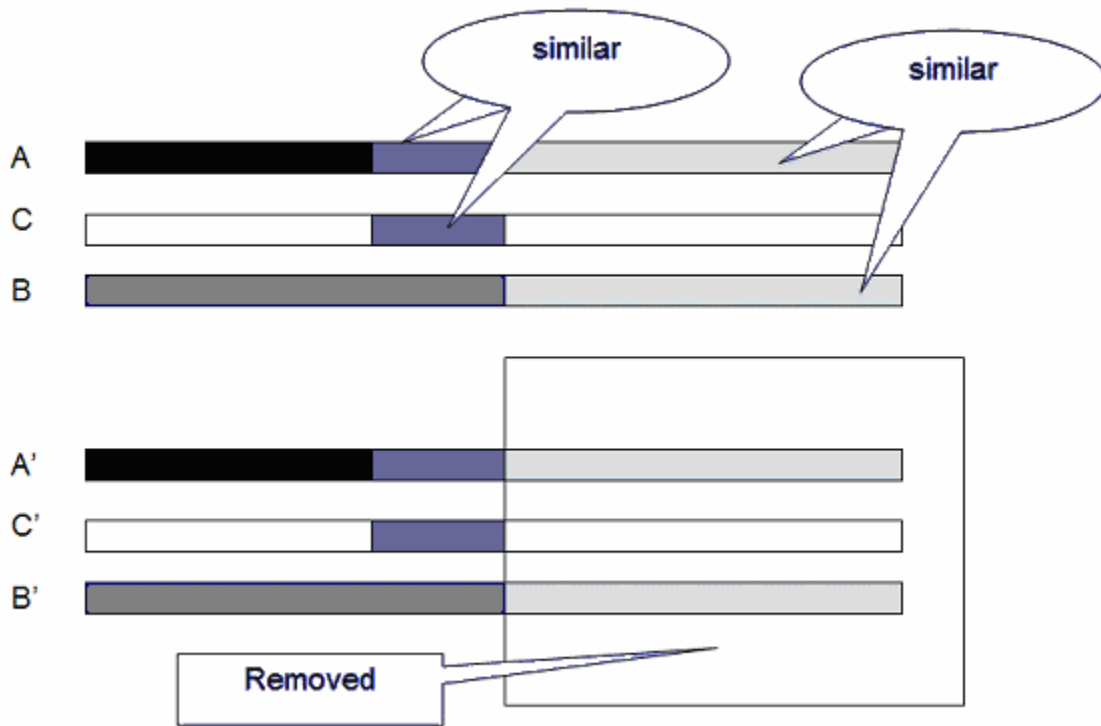

Figure 5.

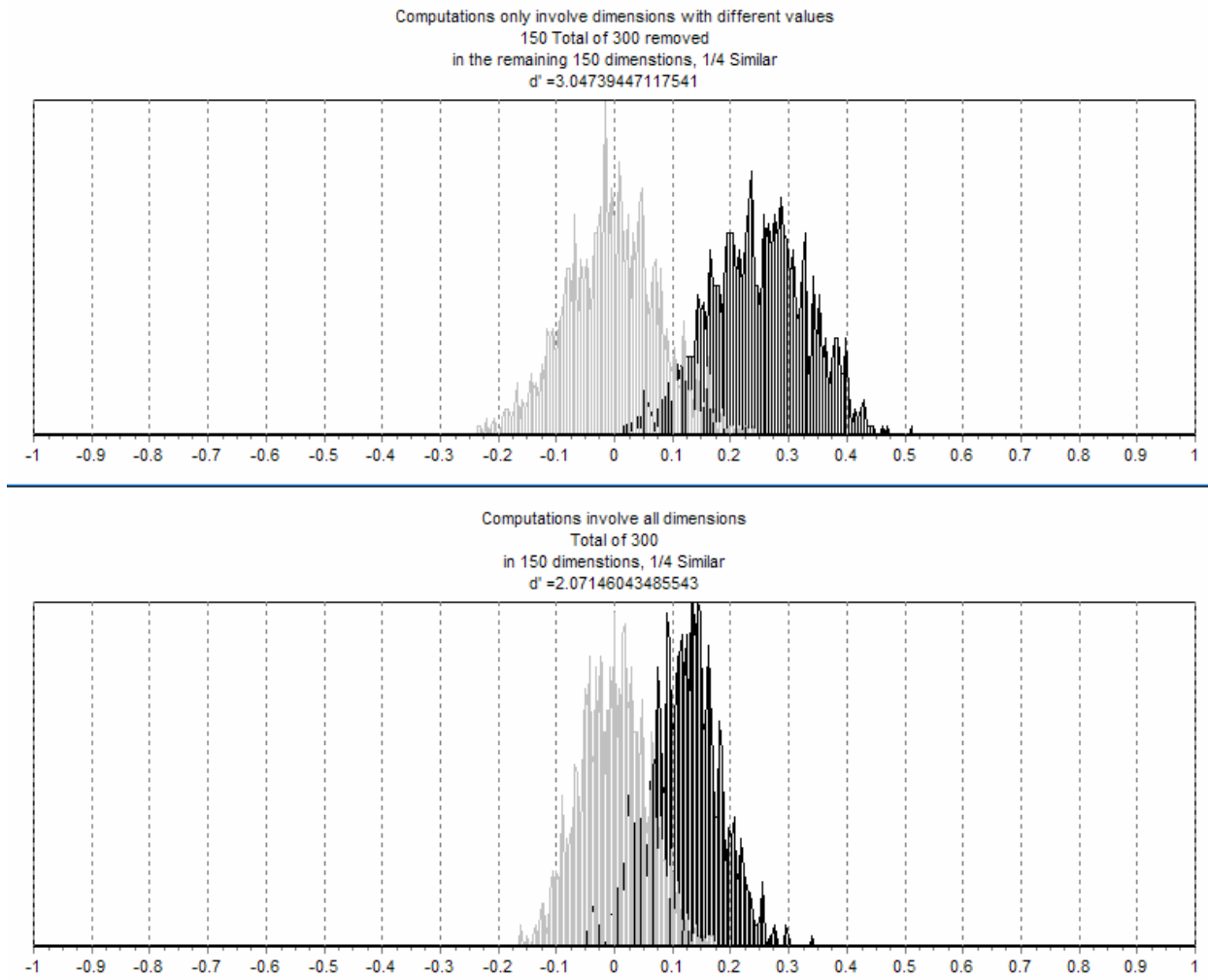

Figure 6.